

# VEMS DASH7" Gen2

for VEMS ECUs

Digital Dashboard for standalone ECUs VEMS V3.x



## INSTALLATION AND USER MANUAL

For model: HW23/12560N7PAIO Rev3 with ODO METER

5th revision 10/2024

# Content

1. Introduction
  - a. Main parts of display unit
2. Main Connector Pinout
3. Base connection of DASH7
  - a. Base connection WIRING DIAGRAM
  - b. Important Warnings
  - c. Buttons connection
4. Full connection of DASH7
  - a. Analog Inputs for 0-5V sensors
  - b. Digital Inputs for vehicle lights status (+12V)
  - c. Digital inputs switched to Ground
5. Controls
  - a. Quick access functions
  - b. Menu navigation
  - c. Remote control
6. Graphic User Interface
  - a. GUI update procedure
7. SD Card Full-Datalogger
  - a. Datalogger connection
  - b. Datalog file name
8. Tuning cable
9. Mounting and Maintenance
  - a. Mounting
  - b. Maintenance
10. Troubleshooting
11. Warranty conditions and Warranty Card

# 1. Introduction

## 1.a) Main parts of V3MS Dash7" Gen2:

1. V3MS DASH7" composite plastic body
2. High-brightness 7-inch TFT screen
3. Shift-light LED diodes
4. Warning LED diodes
5. Micro SD Card slot for GUI upgrade
6. Speaker ("buzzer")
7. Mounting terminals 4x M5
8. CR1220 Clock Battery
9. Main connector (35pin)

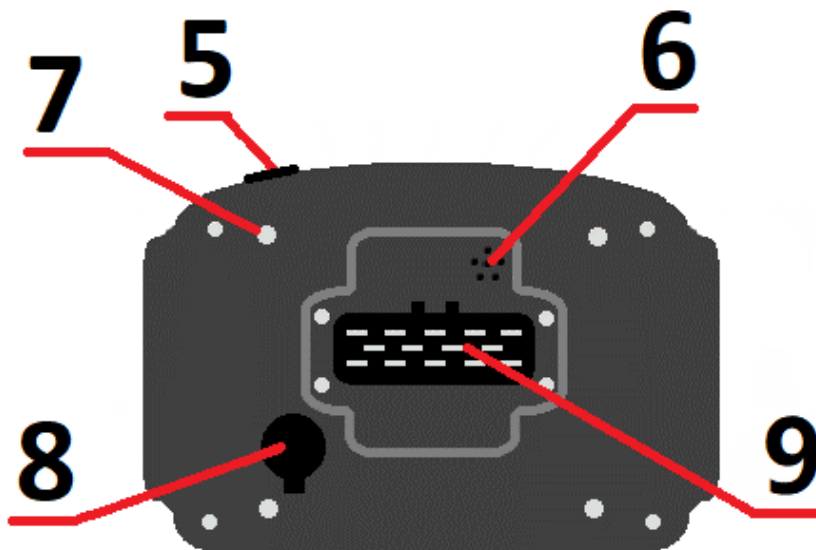

## 2. Main Connector Pinout V3MS Dash7" Gen2

Main connector is used for connecting power supply, ECU communication, analog/digital inputs and control buttons to the Dash7"Gen2. View on the main connector (male) from rear side of the Dash7" (Follow the numbers on the connector).

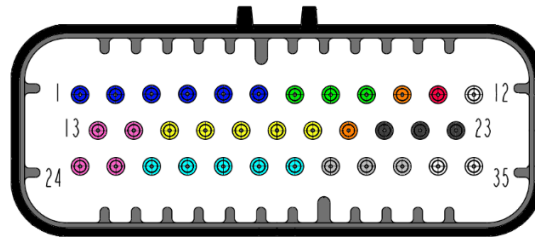

### Row 1

- Pin 1: Button UP (input switched to GND) – green wire
- Pin 2: Button RIGHT (input switched to GND) – yellow wire
- Pin 3: Button LEFT (input switched to GND) – blue wire
- Pin 4: Button DOWN (input switched to GND) – red wire
- Pin 5: Button OK (input switched to GND) – white wire
- Pin 6: Button's common GND – black wire
- Pin 7: VEMS Serial RS232 data (DSUB9 pin 2 or ECU pin 15/EC18 connector) – green wire
- Pin 8: VEMS Serial RS232 data (DSUB9 pin 3 or ECU pin 14/EC18 connector) – white wire
- Pin 9: VEMS Serial RS232 Ground (DSUB9 pin 5 or ECU GND pin 26/EC36 connector) – black wire
- Pin 10: Sensors +5V supply (total load: max. 300mA)
- Pin 11: +12V Key (Switched power supply) – connect this pin to the main or ignition switch in your car
- Pin 12: +12V Batt. (Backup power supply) – this pin MUST BE CONNECTED DIRECTLY to the positive terminal of the battery

### Row 2

- Pin 13: USB D- (pin used for firmware update thru USB connector) - white wire
- Pin 14: USB D+ (pin used for firmware update thru USB connector) – blue wire
- Pin 15: Analog Input 1 (Pressure sensor input) 0-5V, 2k7 internal PullUp resistor
- Pin 16: Analog Input 2 (Temperature sensor input) 0-5V, 2k7 internal PullUp resistor
- Pin 17: Analog Input 3 (Configurable input) 0-5V, 2k7 internal PullUp resistor
- Pin 18: Analog Input 9 (Brightness sensor input) 0-5V, 10k PullUp/PullDown resistor
- Pin 19: Fuel level sensor Input 0-5V, 1MOhm internal PullDown resistor
- Pin 20: Sensors +5V supply (total load max. 300mA)
- Pin 21: Ground (GND for sensors)
- Pin 22: Ground for Datalogger module (black wire)
- Pin 23: Ground (Main power supply GND) – connect to the battery negative terminal or vehicle ground

### Row 3

- Pin 24: USB GND (pin used for firmware update thru USB connector) – black wire
- Pin 25: USB VBUS and Datalogger module +5V Power supply (red wire)
- Pin 26: Input 4 (Low Beam lights +12V) – connect to the +12V of low beam light bulb
- Pin 27: Input 5 (High Beam lights +12V) – connect to the +12V of high beam light bulb
- Pin 28: Input 6 (LEFT Turn Indicator light +12V) – connect to the +12V of left turn ind. bulb
- Pin 29: Input 7 (RIGHT Turn Indicator light +12V) – connect to the +12V of right turn ind. bulb
- Pin 30: Input 8 (Reverse Gear lights +12V) – connect to the +12V of reverse light bulb
- Pin 31: Digital input 1 (Handbrake - GND) – switch ONLY to Ground. Do not tolerate more than +5V !
- Pin 32: Digital Input 2 (Oil Pressure Switch - GND) – switch ONLY to Ground. Do not tolerate more than +5V !
- Pin 33: N.C.
- Pin 34: Datalogger – Data output 1 (green wire)
- Pin 35: Datalogger – Data output 2 (white wire)

**NOTE:** "N.C." means that the pin is Not Connected. "GND" means „Vehicle ground“, a point on the body or frame or on the engine block connected to the negative battery terminal. Best grounding point should be the same where the ECU is grounded. For connecting the main power ground use pin 23 on the Dash7" connector. "+12V" means positive battery voltage ( 9 - 16 Volts). When installing pins into the connector double check that all pins are installed in the correct slot, as the incorrect wiring can damage your Dash7" !

When installing the pins to the female connector, it is necessary to slightly pull out the red cover of the connector (first you need to loosen the locks on the sides). Insert the crimped pin into the slot until you hear a click. After installing all the necessary pins, push the red cover back to its original position. Check if all pins are locked on it's positions and aligned at the same level. Check if they are secured in theirs position by gently pulling the wires from the other side of the connector.

### 3. Base connection of the V3MS DASH7" Gen2

Base connection is used when customer want only to visualise data from VEMS ECU without any additional analog or digital inputs connected to the Dash7".

#### FOR BASE CONNECTION FOLLOW THESE STEPS:

1. Install your Dash7" on its place in the dashboard
2. Prepare 2 wires (eg. black and red) long enough to achieve from Dash7" to the power and ground points in your car
3. Prepare wires for RS232 and for buttons of remote control (they can already be crimped from factory)
4. Crimp pins to all necessary wires and insert them into the dedicated slots of unlocked 35pin female connector
5. Lock 35pin female connector and insert it to the male connector on the back side of the Dash7" unit
6. Turn OFF power supply (turn off battery kill switch, main switch,etc...)
7. Plug in Dash7" RS232 cable to the RS232 connector of your VEMS ECU (NOT THE CONNECTOR NAMED "LCD" !!!)
8. Connect GND wire from pin 23 of main connector to the vehicle's GROUND point or battery NEGATIVE terminal
9. Connect Power supply wire from pin 11 (through 1 Amp fuse) to the main switch or ignition switch of +12V battery voltage
10. Connect Power supply wire from pin 12 (through 1 Amp fuse) directly to the +12V battery terminal. This wire must be under voltage even if battery main switch is turned OFF. (Essential for correct function of the Dash7")
11. If all connections are proper, turn ON the power supply. The Dash7" opening ceremony should begin.

Opening ceremony means that the screen of Dash7" will show you a Startup screen with "logo" (or short video), then you will see a Connect screen for the moment and at the same time all LEDs gradually lights up in Red, Green and Blue color. At the end of the opening ceremony, all the LEDs will go out and the data page with ECU data will be displayed on the screen of Dash7".

You can switch between data pages and change settings of the Dash7" by using buttons connected to the main connector on the back side of the Dash7".

The wiring diagram of BASE CONNECTION is on the picture below.

#### 3.a) BASE CONNECTION WIRING DIAGRAM OF DASH7

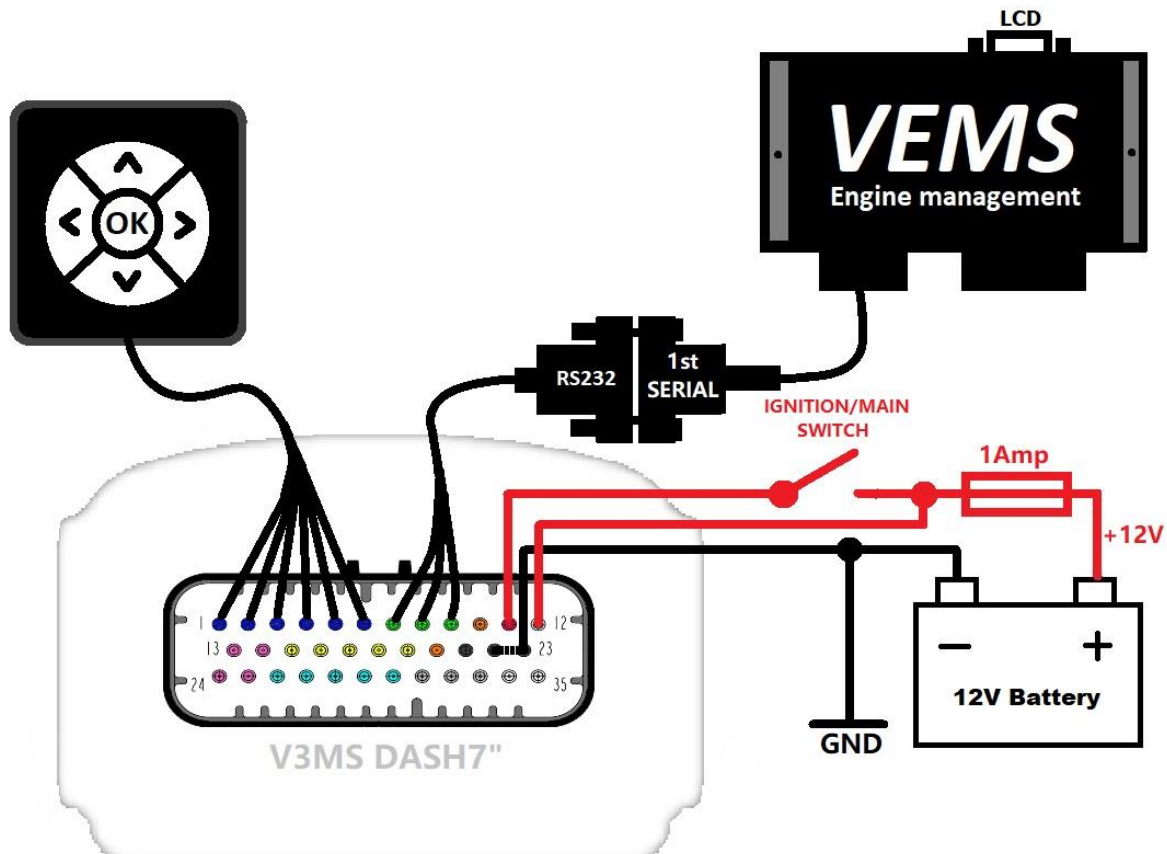

### 3.b.) IMPORTANT WARNINGS, PLEASE READ CAREFULLY !!! :

- NEVER DISCONNECT MAIN CONNECTOR FROM DASH7" WHEN POWER SUPPLY IS ON !
- SUPPLY VOLTAGE MUST BE BETWEEN 9-16V ! (Voltages over 18 Volts can damage your Dash7" !)
- ALWAYS USE 1 Amp fuse for +12V power supply of the Dash7" !
- Locate fuse as close as possible to the source of your power supply to protect wiring in case of shortcircuit
- MAKE SURE THAT YOUR GROUNDING IS PROPERLY CONNECTED !
- MAKE SURE THE MAIN CONNECTOR IS CONNECTED PROPERLY TO DASH7" AND LOCKED IN ITS POSITION
- If possible, always use screws (or other solution) to secure RS232 connectors between ECU and Dash7"
- Make sure, your ECU is not „password protected“. If yes, it does not send out any data through the serial connector (RS232). Your ECU must be „not password protected“ for working with Dash7“. Ask your tuner to unlock your ECU.
- If you are using 3rd party Plug'n'Play Vems ECU (especialy for Porsche) with BT communication, you must disable the internal BT module by removing it from the ECU and wiring a DSUB9 female serial connector from EC18 pins14, 15 and GND. Otherwise, ECU cannot send out any data, because the active internal BT module disable sending data from ECU's serial port.
- Check the version of firmware loaded in your Vems ECU. Dash7" works only with FW in version 1.1.94 or higher. 1.2.31 or higher is recommended.
- Make sure that the Dash7" RS232 connector is connected to the right serial connector of your Vems ECU. Always use ECU's 1st SERIAL connector which is normaly used for tuning the ECU via Laptop. Be careful, because some Vems ECUs may have multiple serial (DSUB9) connectors (marked as "2<sup>nd</sup> Serial" and "LCD"). 2nd serial connector will not work with the Dash7" and LCD connector is dedicated to small liquid crystals display. You should NEVER CONNECT Dash7" to the LCD connector on the ECU!!! Otherwise you very likely damage the Dash7" communication chip!
- Power supply pins are overvoltage and polarity protected, but we strongly recommend to check if all connections follows supplied pinout before turning the power supply ON.
- When performing any bodywork repairs such as welding or spray painting, the Dash7" and other ECUs should be removed from the vehicle to protect them from static electricity or high voltage discharges which may occurs during this work. Simply disconnecting the battery ground wire may not be sufficient protection in some cases.

### 3.c) Buttons connection

Buttons are used to control the main functions of the Dash7, like: switching screens, adjusting brightness, hide warnings, change settings, etc... . Without buttons connected, the Dash7 will work normally (will show data), but you will be unable to control it's functions, switch between pages or change settings in menu. Depends on your order specifications, your Dash7" was delivered with or without control buttons. If you ordered Dash7" without buttons, you can use your own buttons or order them later from our web site. If you want to connect any buttons to the Dash7", use this diagram to wire them. All buttons are switched to „button's ground“ (use a pin 6 of the 35pin main connector to provide common ground for buttons).

Pin 1 = Button UP – green wire

Pin 2 = Button RIGHT – yellow wire

Pin 3 = Button LEFT – blue wire

Pin 4 = Button DOWN – red wire

Pin 5 = Button OK – white wire

Pin 6 = Button's common ground – black wire

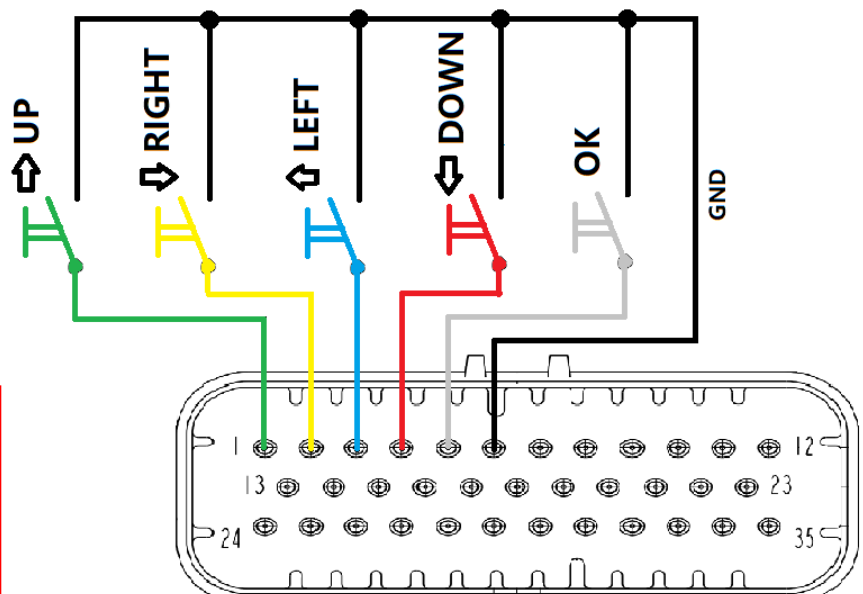

NOTE: If you ordered Dash7 buttons, colors of wires are only informative and may change without prior warning. Actual wires colors are usually written on the button's package. If buttons do not work as expected, please check which wire is connected to the which button with a multimeter.

## 4. Full connection of the DASH7" Gen2

Full connection means a base connection of the Dash7 and a connection of an additional sensors or devices to the inputs of Dash7".

### Inputs :

Dash7" Gen2 can visualize data from ECU, but also from its own analog and digital inputs. Analog (0-5V) inputs are designed to **MAXIMUM OF 5 VOLTS DC**. Inputs are overvoltage protected, but very high voltage could in some cases damage the Dash7", so be very careful when connecting these inputs. For best precision use as a source of +5V for sensors always **pin 10 or pin 20** of Dash7" main connector.

#### 4.A) ANALOG INPUTS (FOR 0-5V SENSORS):

##### *Fuel level sensor (3 wires version – "potentiometer"):*

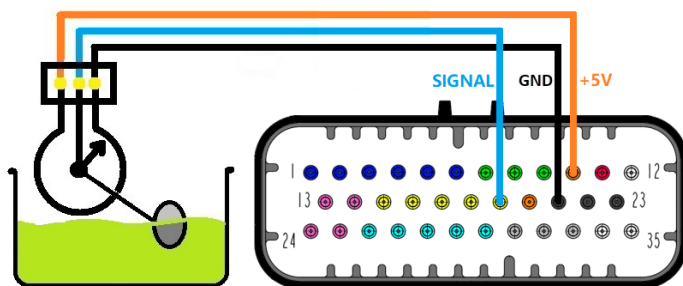

Pin 19: Input signal from Fuel Level Sensor (use 5V and GND supply from Dash7")

Pin 10: +5V power supply for sensors (It is also possible to use a pin 20)

Pin 21: Sensors GND

##### *Fuel level sensor (2 wires version):*

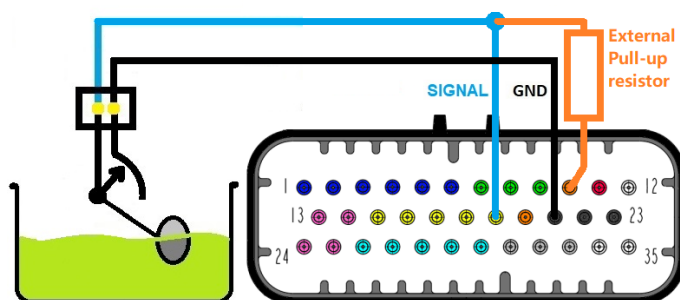

Pin 19: Input signal from Fuel Level Sensor (use 5V and GND supply from Dash7")

Pin 10: +5V power supply for sensors (It is also possible to use a pin 20)

Pin 21: Sensors GND

**NOTE:** If your sensor has only 2 wires, connect one wire to the Sensors GND (pin 21) and another wire to the analog input (pin 19) and add external pull-up resistor between Input (pin 19) and +5V (pin 10 or 20). Resolution of your sensor depends on the value of this pull-up resistor. Use voltage divider calculator to calculate right value for your sensor. (eg. most fuel level sensors have 0-300 Ohm range. Using 100 Ohm pull-up resistor gives you a good resolution (3,75 Volt) from 0 to 100% of sensor movement). Higher pull-up resistance means smaller resolution and lower resistance means higher resolution, but is necessary to be careful when choosing pull-up resistor value! Too small values can overload the 5V circuit! 100 Ohm pull-up resistor means that the max current in circuit will be 50mA. 5V circuit of Dash7" is designed to withstand continuously about 300 mA of total current. Have this in mind when choosing value of pull-up resistors for your sensors.



## Pressure sensor (3 wires version):

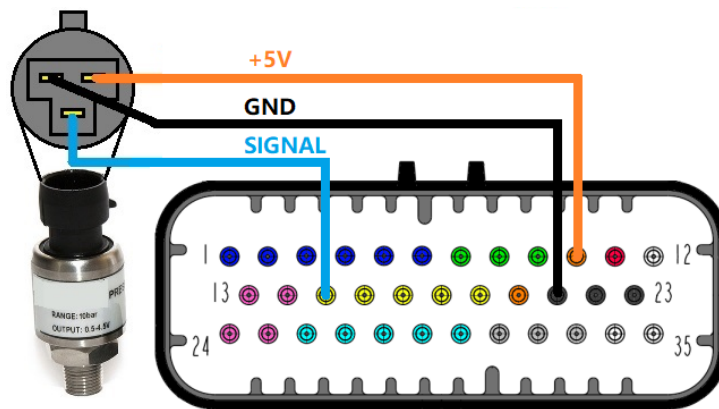

- Pin 15: Input signal from pressure sensor (0-5V)
- Pin 10: +5V power supply for sensors (It is also possible to use a pin 20)
- Pin 21: Sensors GND

**NOTE:** If your pressure sensor has only 2 wires (or even 1 wire) it is usually a resistance based pressure sensor. In the case of 2 wire sensor, connect one wire to the GND (pin 21), another wire to analog input (pin 15). In the case of 1 wire sensor, the ground is connected to the sensor's body thru the engine block, so you need to connect only one wire from the sensor to analog input (pin 15), but be sure that the sensor and Dash7" are connected to the same GND point. 1wire sensors are generally not recommended. External pull-up resistors are usually not needed as the Dash7" have a built in 2k7 pull-up resistor on pin 15 from factory. If your sensor needs a "stronger" pull-up resistor, you must install external pull-up resistor between +5v (pin 10 or 20) and input (pin 15). Value of parallel external pull-up resistor must be calculated. Formula for calculating the external resistor value is:  $Rt = \frac{2700 \cdot R}{2700 + R}$  where Rt is target resistor value for your sensor and R is external resistor value. (eg. for 2k4 target resistance connect 22k external resistor, for 1k target resistance you need 1k6 resistor, for 330 Ohm target resistance you need 380 Ohm resistor, etc...). Avoid too low values (under 100 Ohm), because you could overload the 5V circuit of the Dash7".

## Temperature sensor (NTC):

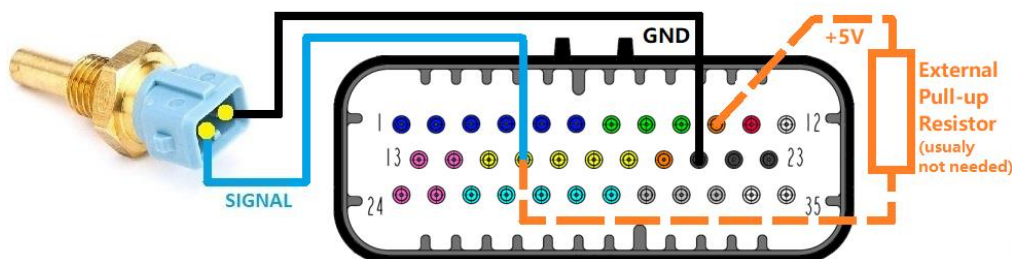

2k7 internal pull-up resistor is installed. Use external pull-up resistor if you need to change pullup resistor value from 2k7 to another. eg. for 2k4 total resistance use 22k external resistor

- Pin 16: Input from Temperature Sensor 0-5V calibrable by 17-point curve
- Pin 10: +5V power supply for sensors (It is also possible to use a pin 20)
- Pin 21: Sensors GND

**NOTE:** In the case of 1 wire sensor, the ground is connected to the sensor's body thru the engine block, so you need to connect only one wire from the sensor to analog input (pin 16), but be sure that the sensor and Dash7" are connected to the same GND point. 1wire sensors are generally not recommended. In most cases, external pull-up resistors are not needed as the Dash7" have a built in 2k7 pull-up resistor on pin 16 from factory. Some sensors needs "stronger" pull-up resistor. You should find the recommended value of pull-up resistor in the sensor's datasheet or manufacturer's documentation. External pull-up resistor must be installed between +5v (pin 10 or 20) and input (pin 16) as on picture above. Value of parallel external pull-up resistor must be calculated. Formula for calculating the external resistor value is:  $Rt = \frac{2700 \cdot R}{2700 + R}$  where Rt is target resistor value for your sensor and R is external resistor value. (eg. for 2k4 target resistance connect 22k external resistor, for 1k target resistance you need 1k6 resistor, for 330 Ohm target resistance you need 380 Ohm resistor, etc...). Avoid too low values (under 100 Ohm), because you could overload the 5V circuit of the Dash7".



## ***Gear position sensor, Neutral sensor or Any 0-5V sensor (Configurable input pin):***

This input can be used with many types of sensors. Can be used for another pressure sensor, another temperature sensor or for position sensor,...etc, with 0-5V output. This input can be also used for GEAR POSITION SENSOR (eg. Drum sensor used in sequential gearboxes) or also can be used like a virtual digital input for NEUTRAL GEAR SWITCH.

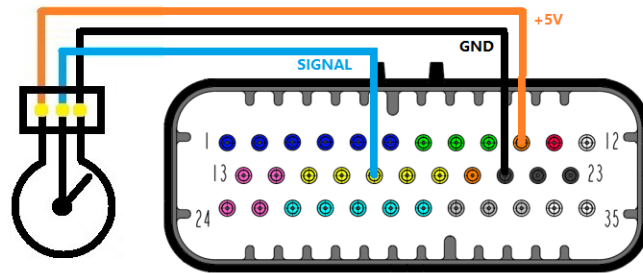

**Pin 17: Configurable Input** – you can use this input for any sensor connected as shown (as a voltage divider 0-5V) or switched to ground or for 3-wire pressure sensors

**Pin 10: +5V power supply for sensors (It is also possible to use a pin 20)**

**Pin 21: Sensors GND**

**NOTE:** If your sensor has only 2 wires, connect one wire to the GND (pin 21), another wire to analog input (pin 17). External pull-up resistors are usually not needed as the Dash7" have a built in 2k7 pull-up resistor on pin 17 from factory. If your sensor needs a "stronger" pull-up resistor, you must install external pull-up resistor between +5v (pin 10 or 20) and input (pin 17). You should find the recommended value of pull-up resistor in the sensor's datasheet or manufacturer's documentation. Value of parallel external pull-up resistor must be calculated. Formula for calculating the external resistor value is:  $Rt = \frac{2700 \cdot R}{2700 + R}$  where Rt is target resistor value for your sensor and R is external resistor value. (eg. for 2k4 target resistance connect 22k external resistor, for 1k target resistance you need 1k6 resistor, for 330 Ohm target resistance you need 380 Ohm resistor, etc...). Avoid too low values (under 100 Ohm), because you could overload the 5V circuit of the Dash7".

If Configurable input pin is used like a digital input for Neutral switch, connect one side of Neutral switch to the GND (pin 21) and another side of switch to the input (pin 17). Neutral switch voltage threshold can be set in the menu "Gauges", under "Gear Channel Calibration".

If Configurable input pin is used for gear position sensor, connect the sensor as on picture above and for proper function go to the menu "Gauges" and then select "Gear Channel Calibration", select strategy "All gears from drumsensor" and as a source select "DASH CONFIGURABLE INPUT" (Analog 3). Then set voltage thresholds for all gears.

If you want to use any other device with 0-5V output as a source for this input, connect GND wire from this device to the GND (pin 21) of the Dash7" and a signal wire (0-5V max) from the device to the pin 17 of the Dash7". Make sure that the output voltage from the device will never exceed 5 Volts and the device must have common ground with Dash7".

### **WARNING:**

EVEN ALL 0-5V ANALOG INPUTS ARE PROTECTED AGAINST OVERVOLTAGE AND CAN TOLERATE VOLTAGES OVER 5 VOLTS WITHOUT DAMAGE, WE RECOMMEND TO ALWAYS DOUBLE CHECK THE WIRING AND DO NOT EXCEED 5 VOLTS ON ANALOG INPUTS. ALSO AVOID TO EXCEED ABSOLUTE MAXIMUM OF 16 VOLTS ON ANY OF THE DASH7" PINS !

## 4.b) DIGITAL INPUTS FOR DISPLAYING THE VEHICLE LIGHTS STATUS (+12V DIGITAL INPUTS)

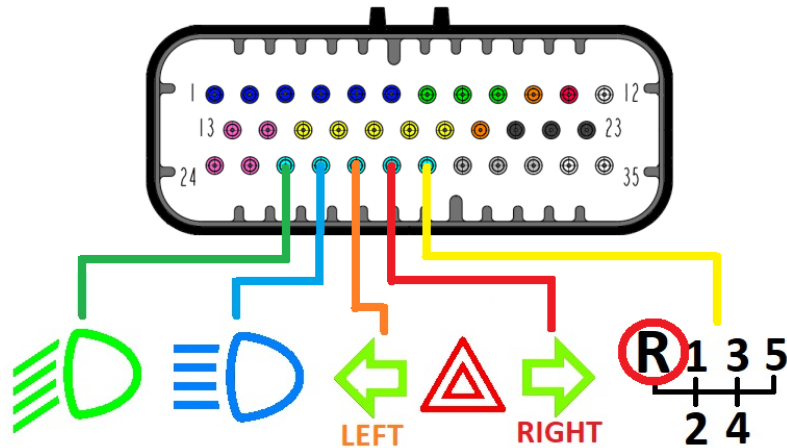

- Pin 26: Input 4 (Low Beam lights +12V)**
- Pin 27: Input 5 (High Beam lights +12V)**
- Pin 28: Input 6 (Turn signal light LEFT SIDE +12V)**
- Pin 29: Input 7 (Turn signal light RIGHT SIDE +12V)**
- Pin 30: Input 8 (Reversing lights +12V)**

Connect wires directly from positive terminals of the bulbs to the Main 35pin connector.

When the lights on car turns ON (+12V applied to the input), indicator on the display or warning LED on the Dash7" also turns ON. The hazard warning light indicator will automatically turn ON when both sides of the turn signals are flashing.

### **WARNING!**

**NEVER EXCEED 16 Volts on the +12V inputs (or any other Dash7" pin)! It may permanently damage your Dash7"!**

## 4.c) DIGITAL INPUTS SWITCHED TO GROUND (GND DIGITAL INPUTS):

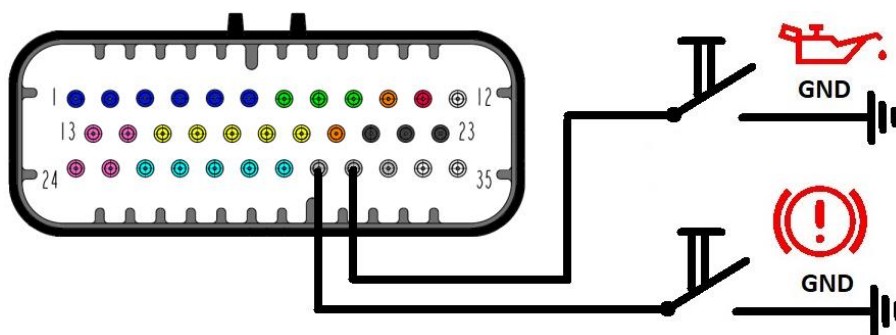

- Pin 31: Handbrake input (switched to ground)**
- Pin 32: Oil Press Switch (switched to ground)**

Operation: When input is connected to the ground, indicator on the screen or LED will turns ON. These inputs has internal pull-up resistors.

### **WARNING!**

**THESE PINS MUST BE SWITCHED TO GND ONLY! EVEN ALL INPUTS ARE PROTECTED AGAINST OVERVOLTAGE AND SHOULD TOLERATE VOLTAGES OVER 5 VOLTS WITHOUT DAMAGE, WE RECOMMEND TO ALWAYS DOUBLE CHECK THE WIRING AND DO NOT EXCEED 5 VOLTS ON THESE INPUTS. ALSO AVOID TO EXCEED ABSOLUTE MAXIMUM OF 16 VOLTS ON ANY OF THE DASH7" PINS !**

## 5. Controls

### 5.a) Quick Access functions

Main controls of display can be reached from any data page by QUICK ACCESS FUNCTIONS.

For reaching quick access functions you can use control buttons on the remote control.

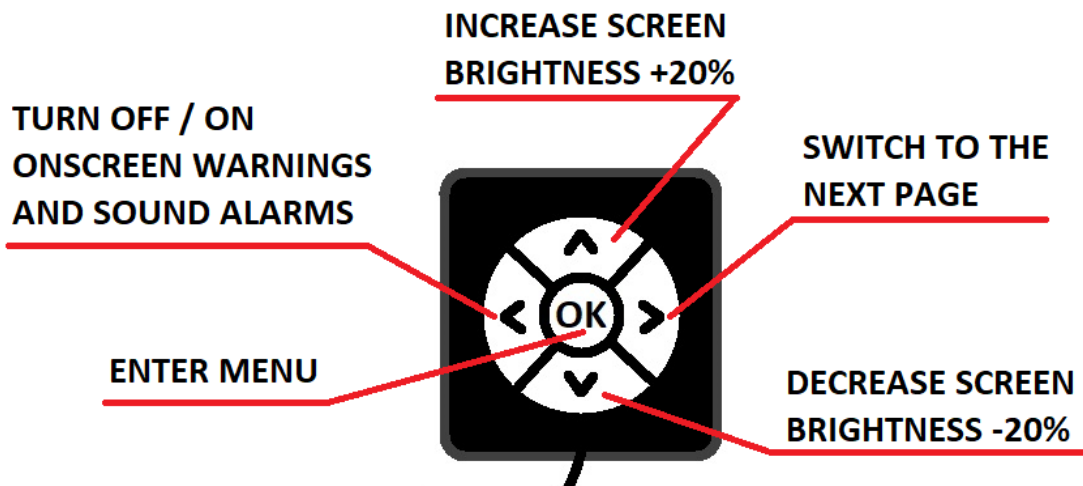

**NOTE:** Please, pay full attention to driving the vehicle and use quick access functions only at the safe places on track or street !

Quick Acces functions only change parameters, but do not save their values to the memory. So, changes are valide only till the Dash7" is powered ON. After you turn the device OFF, parameters will be reset to their last saved values.

**TIP:** If you want to change values (eg. brightness) permanently, change them in the MENU and SAVE them.

### 5.b) Menu navigation

After pushing OK button, you will access the MENU. On every menu page you can navigate cursor by arrows and confirm (or change color) by OK button. Every menu page is different, so there is a HELP TEXT on every page. Help text is written in green color and give you an information about the button's function on the actual page.

### 5.c) Remote control

Remote control buttons can be purchased as individual buttons, buttons on PCB, or as a buttons encased in the plastic case. The plastic case can be mounted anywhere in the interior of the car. In the lower part of this plastic case, the wires come out. For better integration into the cockpit, the user can choose the orientation of the remote control. So the buttons can be installed with the wires exiting at the top, bottom or sides. After mounting the box in the desired position, you can insert the "OK" button in the correct position. In the menu "Display", you can set the Remote control orientation to 0°, 90°, 180° or 270°, depending on how you actually mounted it in the car.

## 6. Graphic User Interface (GUI)

Dash7" has unique Graphic User Interface. GUI consists of Startup page with customised logo, Connection page, menu pages and 5 fully customised data pages. Data pages and Startup page can be completely customised. You can download templates or create your own design in our V3MS Web Dash Designer. You can use your own logo (picture or short video) at the Startup page . Also you can add a small logo at any data page you like.

After creating GUI in Web Dash Designer, just send it to us and after validating we will send you a file. Upload this file to the microSD card, insert the card to the SDcard adapter delivered together with your Dash7, put the adapter to the Dash7 SDcard port located on the top of the display unit (with QR code or label faced to you) and upload your new GUI to the device. Below you can find step by step instructions how to perform GUI update.

### 6.a) GUI Update procedure:

1. Turn OFF the Dash7" (turn OFF ignition or another switch which cuts power supply to the Dash7")
2. Insert microSD card to your PC and load new GUI file (\*.TFT) to the SD card
3. Insert the microSD card with a new GUI file to the SD card extension adapter delivered with your Dash7" (card must be FAT32 formatted and only one GUI file must be loaded into a root directory)
4. Remove a dust protection cap from SD card slot located at the top of the Dash7"
5. Gently insert SD card exteder adapter with microSD card to the SD card slot ( QR code on extension faced to you). A click is heard when the adapter is inserted and the adapter remains locked in the holder.
6. Turn ON power to the Dash7"
7. Update will start immediately. You will see a white screen with red letters and numbers. After few seconds screen will show message „100%" and „Update Succesfull"
8. Turn OFF Dash7"
9. Push gently down the SD card extension adapter and release it from the Dash7"
10. After the SDcard was removed, insert a dust protection cap back to its place and turn ON the power supply of your Dash7"
11. Done. Now you should see your new GUI

**NOTE:** In some cases, when Dash7" was not updated for a long time, after restart a white screen could be displayed again with message „firmware upgrade". It is normal and after few seconds your new GUI will be displayed. If not, please restart Dash7" again. After restart device should work normal and will display your new GUI.

## 7. SD Card Full-datalogger (optional):

If Dash7" was ordered with Full-datalogger option, you can save essential data from the ECU to the SD Card during driving. As a memory card should be used TF cards (microSD) with capacity up to 8GB (some Class10 cards working well also up to 32GB) formatted FAT32. Card slot is on the side of the datalogger's plastic case. For better manipulation with SD card you can insert your microSD card to the "SD card extension adapter" delivered with your Dash7" and then insert it to the datalogger (may not be a good solution for an environment with high vibrations).

### 7.a) Connection of full-datalogger

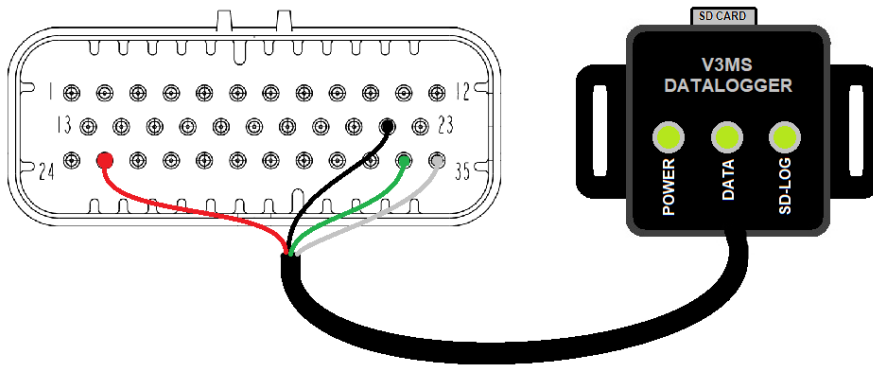

- Pin 22: Ground for datalogger
- Pin 25: +5V power supply for datalogger
- Pin 34: Data 1
- Pin 35: Data 2

#### Start Logging

For start logging only put your SD Card to the slot and set the action when log should start in the "DATA LOG" menu of the Dash7", return to main menu and restart Dash7".

You can set start logging at:

- **After power ON** (new file will be created at every Dash7" power ON cycle, after first data from ECU are received)
- **When engine is running, RPM > 0** (new file will be created every time when engine RPM rises above 0 RPM)
- **When car is moving, Speed > 0** (depending on Wheel speed 1 or 2) (new file will be created every time when car starts moving)

#### Data logging

When datalog function is active, you can see a small icon (Green circle with word LOG,  depending on GUI version) in the corner of your screen. If this icon is not visible, Dash7" logging to the SD card is not active. This can happen probably because the conditions for enabling datalogger are not reached.

NOTE: „Log“ icon on the screen only indicates that the Dash7" sent the request to the datalogger because conditions for logging was reached, but does not indicate that the data logger physically write data on the SD card! You can see if datalogger is writing data on SD card by checking if green LED „SD-LOG“ on the datalogger body is flashing.

On the top of the datalogger plastic body there are 3 LEDs: POWER, DATA and SD-LOG. These LEDs are indicating states of datalogger. If "POWER" LED is shining bright green, it means that the Datalogger has power from Dash7". If "DATA" LED is flashing green (flashing can be poor), it indicates that the Dash7" is sending data to datalogger. If LED "SD-LOG" is flashing bright green, it means that the datalogger is writing data to the SD Card. If "SD-LOG" LED is OFF, it means that the condition for logging are not reached or SD card is not inserted, not inserted right or card is damaged, incompatible or not formatted right.

**WARNING!** SD Card must be formatted FAT16 or FAT 32 (prefer FAT32) . Use only SD cards with capacity up to 8GB (some microSD HC Class10 cards with SD adapter could working well up to 32GB).  
From Datalogger's FW V1.1.0: If SD card was removed during logging, inserting card back to the slot will create a new file on SD card and logging starts again. On older FWs, you must reset the Dash7" if card was removed!

## 7.b) Datalog file name

Files are saved on the SDcard in CSV format which allows you to open these files in many log viewers (eg. MegaLogViewer) or in other software (eg. Excel, Word, Notepad, etc...). Files are named "LogXXXX.csv", where XXXX is sequence number from 0001 to 9999 for every new file. Datalogger always check the SDcard and start searching from the filename Log0001. If the file with that number does not exist, Dash7" will create it and starts logging data to that file. For better clarity and SD card longlife, we recommend not deleting the files from the card, but leaving them there until the card is not almost full. If you decide to delete files from the card or copy them to the PC, we recommend doing so with all files so that the card remains empty. This avoids mixing up files from several days or runs. The data files are in compact size (about 7MB for 1 hour of recording), so if you have a big enough SD card, you can record on it for several weeks, months or even years. 32GB SD card is capable to store more than 4800 hours of data, what is 200 days (24 hours per day) or 600 working days (8 hours per day). If the number of files on the SD card exceeds 9999, a "lastlog.csv" file will be created. This file will always be overwritten with the latest data every time the new logging action start.

## 8. Tuning cable (optional)

Tuning cable is data splitter cable which allows user to tune the ECU via laptop (PC) and simultaneously watch data on the Dash7".

This can help tuner to have more data (some kind of data can be showed on laptop and another data on the Dash7") and also can prevent some engine damage, because Dash7" can perform visual and acoustic alarms if any of measured parameters (pressure, temperature, fuel level,...) is out of its safe limits.

### Quick guide for working with Tuning cable:

- 1.) Connect MALE connector of Tuning cable marked „ECU“ to the Vems ECU RS232 connector (NOT LCD CONNECTOR!)
- 2.) Connect FEMALE connector of Tuning cable marked „PC“ to the PC serial port (if there is no physical serial port on your PC, use RS232 to USB converter)
- 3.) Connect FEMALE connector of Tuning cable marked „DASH“ to the Dash7" RS232 communication connector
- 4.) Start Vemstune software on your PC
- 5.) Turn ON Vems ECU and Dash7" dashboard
- 6.) Wait until the ECU log into the Vemstune
- 7.) DONE!

Data should be now visible on both devices.

### Tuning cable connection to PC and Dash7"

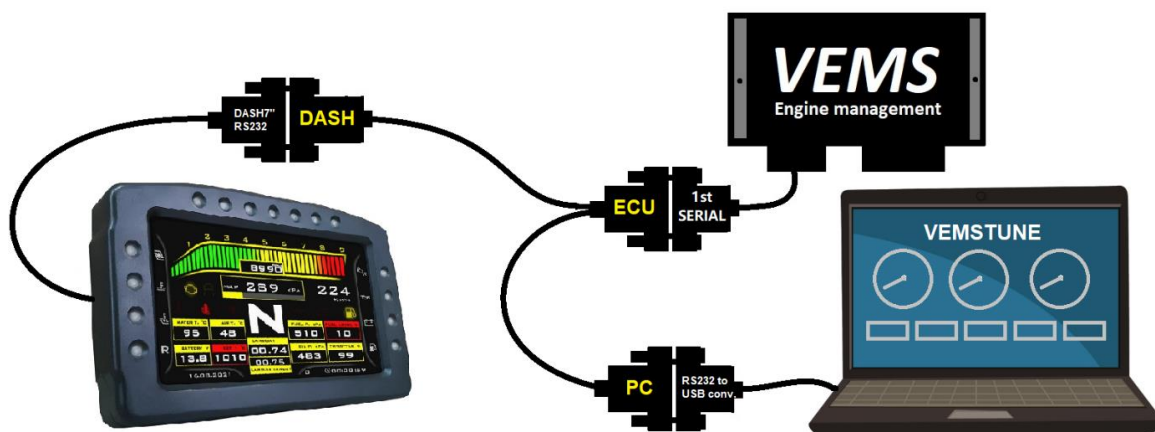

**TIP:** After the tuning session, unplug the Tuning cable and plug Dash7" directly to the Vems ECU.

If you want, you can leave a Tuning cable plugged into the ECU, but you need to unplug the Dash7" from the „DASH“ connector and plug it into the „PC“ connector of Tuning cable.

**IMPORTANT NOTE:** It's normal that the Dash7" displays some warning messages when Vemstune is logging into the ECU or when burning data (it's because the data are corrupted for that moment). Please note that with Tuning cable connected, the Dash7" can show data from ECU only when Vemstune software is connected to the ECU!



## 9. Mounting and Maintenance

### 9.a) Mounting

Mount the Dash7" in car interior in a place where you will have an unobstructed view to the screen and LEDs while driving.

The Dash7" is designed for mounting to the dashboard panel or holder (not included), using 4x M5 screws located on the back side of the unit.

**When mounting Dash7", make sure that there is enough space on the back for the connector and wiring!**

**WARNING!** Although the Dash7" units is sealed, it is NOT considered as a rainproof, waterproof or water-resistant device! Using the device in wet conditions is at customer's own risk and the damage by moisture or liquids is NOT covered by factory warranty !

#### Mounting conditions:

- Before installation, unplug the car's battery positive or negative terminal
- If possible, mount the Dash7" on the place where it will not be exposed to a direct sunlight or other heat source. Do not expose Dash7" to temperatures above 75 ° C (167 ° F)
- Never mount the Dash7" on places where it can be exposed to the rain or water!
- Position the cables and connectors in such a way that they cannot be damaged
- Adjust the tilt of the display for the best visibility and lock it in this position
- Place the Dash7" in the holder or panel and tighten the M5 nuts on the back of the Dash7" to max 6 Nm!
- After mounting the Dash7", connect the main connector (35 pin)
- Position the cables and connectors in such a way that they cannot be damaged or exposed to heat
- **DOUBLE CHECK WIRING AND CONNECTIONS!**
- **AFTER DOUBLE CHECKING you can turn ON the ignition** (or other) switch which turns ON the Dash7".
- If everything is working correctly, you can now remove the protective film from the screen, set some parameters in MENU and enjoy your Dash7".

### 9.b) Maintenance

Dash7 does not need during its life any special maintenance. Just keep device and connectors clean and protected against corrosion and keep wiring harnesses in good condition. It is also necessary to keep device away from high temperatures, high humidity or extreme vibrations. After a few years it could be also necessary to change the real time clock battery.

**Clean Dash7 body and screen only with a slightly wet towel (soft cloth or paper towel) which can't scratch the surface.**

**WARNING!** NEVER USE acids, solvents, thinners, gasoline, alcohol or other aggressive cleaning agents for cleaning the Dash7", otherwise you can totally damage the screen or other parts of the Dash7" !!!

**WARNING!** IS HIGHLY RECOMMENDED TO ALWAYS DISCONNECT AND REMOVE THE DASH7" FROM VEHICLE WHEN WELDING ON OR NEAR THE VEHICLE! Otherwise, Dash7" (or any other ECU in vehicle) may be damaged by high current or electro-static charge! This type of damage is not covered by warranty.

For long life, if possible, set screen brightness and LEDs brightness to about 50-60% of their full capacity. At 50% brightness this parts should have a 20 000+ hours service life. Higher brightness shortens their service life.

## 10. TROUBLESHOOTING:

- 1. Power is turned ON, but the screen is dark and LEDs are OFF:** Dash7 probably has no power. Check your power supply, fuses and pins in the connector. With ignition ON, check if voltage between pins 11 and 23 on the main connector is the same as car's battery voltage (usually 12-14V, must not be less than 9 and more than 16 Volts!) and if polarity is not reversed. Check the voltage also between pins 12 and 23. If there is no voltage, check grounding, fuses and switches. If everything is as described, contact our tech support.
- 2. Text "INITIALIZING" is flashing more than 3 seconds and message "INITIALIZATION FAILURE" is displayed:** This should happen only during Dash7" firmware upgrade process. If this happen during normal operation, contact our tech support.
- 3. Text "ECU DISCONNECTED" is displayed on the screen:** There is probably a missing connection between the Dash7" and the ECU or there is no data coming from the ECU or communication cable is inserted into the wrong connector. Check connection between Dash7" and the VEMS ECU (RS232 connector) and check if ECU is powered ON. Check if RS232 connector from the Dash7" is connected to the RS232 connector of the 1<sup>st</sup> serial port on the ECU side. Some ECU may have more than just one RS232 connector. There can be 2<sup>nd</sup> serial connector and LCD connector. NEVER USE THESE CONNECTORS!!! LCD connector may kill the communication chip in the Dash7"! Next, check if your ECU is not "PASSWORD PROTECTED". If yes, disable password protection (or ask your tuner), because with password protection activated the ECU do not send out any data in Triggerframe protocol. Next, check the version of the firmware loaded in your Vems ECU. Dash7" works only with FW in version 1.1.94 or higher. 1.2.31 or higher is recommended for best result. If you have 3<sup>rd</sup> party Plug'n'Play ECU (especially for Porsche) with internal BT module, this module must be disconnected, because this module causes the ECU do not send out any data via 1<sup>st</sup> serial port. Contact the ECU manufacturer or dealer.
- 4. Dash7" resets, screen flickers or won't start normally:** The Dash7" probably has a low or unstable supply voltage. Dash7 has undervoltage protection function. If voltage drops under 8 volts, the Dash7 turns itself OFF and will wait in this state until the voltage raise to 8,5V or more. Then the Dash7 turns ON itself. Check the quality of the power supply, grounding and battery voltage. Check if Dash7" supply voltage (on pins 11 and 12 towards ground pin 23) during driving is not dropping under 8 volts (normally it should be between 13.5V and 14.5V). If everything is as described, but the problem persists, contact our tech support. NOTE: during cranking, if supply voltage drops under 8 volts the Dash7 could resets. This is a normal condition and it is an undervoltage protection of the Dash7. To prevent this, find the reason why the voltage drops so significantly. Install a new battery, repair the starter motor or check the wiring and grounds.
- 5. Dash7" resets during cranking:** It is normal state when your battery voltage during cranking falls under the safe threshold (approx.. under 8 Volts). This usually happens only when car's battery is not in 100% condition or when starter motor takes too much current during cranking. Dash7" with reset try to safe itself from stuck when supply voltage is too low.
- 6. I can't see any OnScreen Warning Messages (OSW) even when values are out of their limits:** Probably you have turned off displaying OnScreen Warning messages. In the menu "Alarms", check that the "OnScreen Warnings ON/OFF" icon is set to "ON" (icon of the display with a green tick). If not, move your cursor to the "OSW ON/OFF icon" and press OK button to display the icon with a green tick. You should see a message "On Screen Warnings ON". From FW V1.2.2 OSW can be turned off individually for every measurand. Check if the icon of "display with green tick" is next to every measurand for which you want to display the OSW. Warning messages can also be turned off temporarily, if on some data page the user presses the "left arrow" button on the remote control. Then a red crossed-out speaker icon will appear in the corner of the screen. This function is here to fast mute all alarms if some sensor failure and alarms are occurred frequently. To start displaying the OSW messages again, it is enough if the user goes to any data page and press the "left arrow" button on remote control again (a red crossed-out speaker icon will disappear).
- 7. I can't hear any sound when startup or when warning messages are displayed (or the volume is low):** Probably you have your buzzer turned off or a speaker is covered (blocked) by something. In the menu "Alarms", check that the "Alarm Buzzer ON/OFF" icon is set to "ON" (icon of the green speaker). If not, move your cursor to the "Alarm Buzzer ON/OFF icon" and press OK button to display a green speaker icon. From FW V1.2.2 a buzzer can be turned off individually for every measurand. Check if the icon of "green speaker" is next to every measurand for which you want to hear the alarm sound. Buzzer can also be turned off temporarily if on some data page the user presses the "left arrow" button on the remote control. Then a red crossed-out speaker icon will appear in the corner of the screen. To allow buzzer again, it is enough if the user presses the "left arrow" button again (a red crossed-out speaker icon will turn off). If the sound volume is low, check that the speaker (located on the back of the display unit) is not blocked or covered by something. To solve the problem, ensure that the sound can flow freely from the speaker. If everything is as described, but the problem persists, contact our tech support.
- 8. Buttons on remote control are acting in wrong direction:** You probably have the remote control orientation set incorrectly. Go to menu "Display" and change the orientation setting of remote controller. If orientation is set correctly, but problem persist, your remote control buttons are probably wired incorrectly. You can solve the problem by wiring them correctly according to the wiring diagram in section 2/a/ii of this installation and user manual. Check wires with voltmeter for continuity first.
- 9. Cannot control the Dash7" by buttons on the remote controller:** Probably the Dash7" is not connected to the buttons or the wires (especially ground wire) may be faulty. Check if all wires from remote control are connected to the 35pin connector on the back of the Dash7". Check the continuity between pin 6 (Buttons GND) and other pins (1-5) when pressing buttons. If everything is as described and problem persist, contact our tech support.
- 10. GUI update does not start even if the microSD card is inserted to the Dash7":** If microSD card is inserted correctly and after restarting the Dash7 starts normally (not with the white Update screen), the microSD card is probably faulty or not properly formatted, not inserted correctly or the card does not have a valid GUI file (\*.tft) or there are more than a one \*.tft files on the microSD card. If the card is formatted FAT32, insert a card into the computer and check if there is a valid GUI \*.tft file in the root directory. If not, format the card again (with FAT32) and then reload the tft file to the root directory of the card. Then try to upload GUI to the Dash7" again. If update does not start or "update failed" message will appear, try another SD card (or cards) and repeat the whole process again. In rare cases, the SD card adapter may be faulty, but usually the problem is faulty or incorrectly inserted

SD card. A correctly inserted card means that the microSD card is inserted in the extension adapter and the adapter is inserted into the display unit with the QR code facing the user. A click is heard when the adapter is inserted and the adapter remains locked in the holder. If everything is as described, but the problem persists, contact our tech support.

11. **GUI update failed (update failed message on the Update screen):** Probably faulty microSD card, try another card. Even if the card is working fine in PC, it can be faulty! If GUI update failed also on other SD cards, GUI file can be corrupted (very rare). Ask our tech support for a new file.
12. **SD Datalogger is not logging any data, LED "POWER" is not shining:** This means the datalogger don't have a power supply or voltage is insufficient. Check if red wire from datalogger is connected to the pin 25 (this pin is shared with USB VBUS) and if black wire from datalogger is connected to the pin 22 (GND). If yes, measure voltage between these two pins. It should be 4,7-5V
13. **SD Datalogger is not logging data, LED "POWER" is shining, but "SD-LOG" LED is off.** If the LED "SD-LOG" on the main unit is not flashing, it means that no data is being written to the SD card.

Possible causes are:

- No SD card inserted or inserted incorrectly. SD card must be inserted and pushed until a click is heard and card remains locked in holder
- SD card is write-protected. On the side of the SD card is a little switch which can lock the SD card against writing. Slide this switch to the unlocked position.
- SD card is faulty or not formatted correctly to FAT32. Format the SD card to FAT32 or try another card.
- Data logger is turned OFF or conditions for starting logging have not been reached. Go to menu "DATA LOG" and check if item "Start of SD card log" is set to "NEVER". If so, change this setting according to when you want logging to start. You can set it to: "After power ON", which start logging immediately after Dash7 is powered ON. Or you can set it to: "After engine start", which start logging when engine RPM are higher than zero. Or you can set it to: "After Wheelspeed1 (or2) > 0", which start logging when car speed is higher than zero. After changing these settings you must reboot the Dash7
- No connection between the Dash7 and the ECU, or ECU is turned OFF. If no data is available from the ECU, the data logger does not log. Connect the ECU and turn it on. When data starts flowing from the ECU and logging conditions are reached, logging should start. You will see the green icon „LOG" in the corner of the screen and the LED „SD-LOG" on the datalogger should flashing fast.

If you have followed all the steps described above and the problem persists, please contact our tech support.

14. **Alarms occurs even if the sensor for the given measurand is not in use:** This can especially happen when the sensor for a particular channel is not connected (channel is not in use), because a disconnected sensor usually means that the input reading will reach its upper or lowest level (eg. -40°C or +155°C). This value is usually outside the safe thresholds and should normally trigger an alarm (because this feature is commonly used to warn the driver that a connected sensor is faulty or has been accidentally disconnected). A false alarm can also occur if ECU was disconnected and reconnected or if data from ECU are corrupted (eg. very low voltage during cranking, etc). If you want to avoid unwanted alarms from not used channel, solution is to set the thresholds for that measurand to the values which cannot be reached even with disconnected sensor or from FW 1.2.2 there is possibility to enable or disable OSW and/or sound alarm individually for every measurand. Go to menu ALARMS, and press enter on measurand you want to change until you see the green speaker next to it.
15. **When I connect a laptop to the ECU and disconnect a Dash7, it stops to display data on the dash. Can I have connected both, PC and Dash7" to the ECU at the same time?** : Yes, you can have connected your laptop to the Vems ECU, and at the same time you can also watch all data on the Dash7. But you must to use our "Tuning cable" which is available in our shop. This splitter cable allows you simultaneously tune your ECU (or log data to the PC) and display all data and alarms (or also log data to the SD card) on the Dash7. Without this adapter cable you can have connected only one device to your ECU RS232 port at the same time (laptop or Dash7). All information about the Tuning cable you can find in the section "TUNING CABLE" in this manual.
16. **Tuning cable is connected, but not working as expected:** There are usually 3 possible problems with a communication via Tuning cable:
  - **Tuning cable is connected, but I can see the data only on the Dash7 and the VemsTune can't detect the ECU.** You have probably swapped the female connectors of the Tuning cable or tuning cable is not properly connected to the PC or your RS232-USB adapter is not working or wrong port selected in the VemsTune. Connect the female RS232 connector of the Tuning cable (labeled "PC") to a computer's serial port (or via an RS232-USB adapter to a computer's USB port). Then connect another RS232 female connector of the Tuning cable (labeled "DASH") to the Dash7's RS232 male connector. Open the VemsTune, click on the "ECU icon" and then click on "Detect". It should detect the USB port where the ECU is connected. If problem persists, try another RS232-USB adapter (if possible) or try another Tuning cable. If you have followed all the steps correctly but still the problem persists, please contact our technical support.
  - **Tuning cable is connected, but I can see the data only in VemsTune and the Dash7 do not display data from ECU.** Probably the Tuning cable is not properly connected to the Dash7 or Tuning cable (and/or Dash7's serial cable) is faulty or your ECU firmware is very old. Check the connections (RS232 female connector of the Tuning cable, labeled "DASH" must be properly connected to the Dash7's RS232 male connector) and try to restart the Dash7 and the ECU. If the problem persists, try to unconnect the Tuning cable and connect the Dash7 directly to the ECU. If Dash7 is displaying the data from ECU this way and via Tuning cable is not, probably your tuning cable is faulty or your ECU firmware is too old. Please contact our technical support.
  - **Tuning cable is connected, but I can't see any data on the Dash7, even in the VemsTune.** With the Tuning cable connected, you can only see the data on the Dash7 when the VemsTune is connected and communicating with the ECU. If the problem occurs, probably the ECU is not powered ON or the VemsTune is not communicating with the ECU, or the ECU serial port is faulty or not properly connected to the Tuning cable or Tuning cable is faulty. First of all, check again all connections and make sure that the Tuning cable is connected as described above. If ECU is not powered ON, turn it ON,

let it to connect to the VemsTune and see if this solve the problem. If problem persists, open the VemsTune, click on the "ECU icon" and then click on "Detect". It should detect the USB port where the ECU is connected and start communicating with the ECU. If ECU is not detected in VemsTune, unplug the Tuning cable and try to connect the ECU to the PC directly. If communication between ECU and VemsTune works this way, probably your Tuning cable is faulty. If problem persists, contact our technical support.

- 17. When I was burning data to the ECU via Vemstune, sometimes I got OnScreen Warning message on the Dash7 (with Tuning cable connected):** This is normal and it can't be completely eliminated. Usually it is a trigger error warning message. It happens because on a short moment when Vemstune is burning data into the Vems ECU, the data sent from the ECU to the Dash7 are corrupted. Ignore these messages during data burning or during initialization of connection.
- 18. Date and Time displayed on the screen is incorrect:** You don't have set your date and time yet or if problem occurs only after restart the Dash7, the real-time clock (RTC) battery is probably not installed or dead. There is a rubber protective cover on the back of the display unit. Under this cover there is an RTC battery holder. Check if the CR1220 battery is correctly installed in the holder. The battery must be fully inserted and the "+" mark must be visible on the top of the battery. If there is no battery, install a new CR1220 battery in the holder. If there is a battery in the holder, but the wrong type or incorrectly installed, remove this battery and insert a new CR1220 battery in the correct way. If the CR1220 battery is installed correctly, but the time and date are incorrect after the Dash7 restarts, the battery is probably dead and you need to replace it with a new one. A very small screwdriver or small extraction tool is usually required to remove the old battery from the holder. With extraction tool gently push the lock that holds the battery in the holder and the battery will pop out of the holder. Then rotate the display unit until the battery falls out of the battery slot. When installing a new battery, it is sometimes necessary to first gently move the lock to its original position, then insert the new battery (positive side UP) and gently push the battery into the holder until you hear a click and the battery stays locked in place.
- 19. Speed 1 or Speed 2 gauge still shows 0 kmh or mph even if car moves:** You probably don't have a wheel speed sensor connected to the wheel speed input of the Vems ECU, or the sensor is not properly calibrated or faulty or installed incorrectly. Calibration of the wheel speed sensor must be performed in the Vems ECU via Vemstune software. The Dash7 only reads wheel speed values from the ECU and therefore no configuration is required in the Dash7.
- 20. Gear gauge still shows "N" or "R" even when another gear is engaged:** Probably Reverse gear input is shorted to +12V or Neutral gear input (Dash7" configurable input) is shorted to ground or its voltage is out of the threshold. It could be a wiring problem or faulty switch. Check function of reversing lights switch on the gearbox. If faulty, change the switch, if not, check your wiring for short-circuits or bad grounds. Same with the Neutral gear switch (connected to the Dash7" Configurable input pin). If you have followed all the steps described above and the problem persists, please contact our tech support.
- 21. Oil/Fuel Press or Oil/Fuel Temp gauge in Dash7 is showing different values than in Vemstune:** Probably your Pressure or Temperature channels in the Dash7" are not calibrated correctly. Sensor calibration in the Dash7" is independent from ECU's calibration. You need to go to the "Gauges" menu and select the "Press channels calibration" or "Temp channels calibration" button. Then if you press the OK button on the remote control, you will be taken to the calibration pages, where you can set a source channel for that pressure or temperature gauge and calibrate it. As a source you need to select the ECU analog channel to which your sensor is wired (it can be ECU input channel or Dash input channel). Then enter the voltage and pressure (or temperature) values depending on the sensor manufacturer's datasheet (or Vemstune data). If everything is set correctly, exit the menu and you should see the correct values on your pressure or temperature gauges. From FW 1.2.2 you can watch actual channel voltage and calculated pressure value directly in the pressure sensors configuration page.

# 11. Warranty

Factory standard limited warranty is 24 months from the date of delivery.

Warranty covers manufacturing defects and damages created during production or packaging. Warranty does not cover the damage of the device by over-current, over-heating, over-voltage, under-voltage of the device and its inputs, also does not cover any mechanical, electrical or electro-static damages made by consumer or third parties, or by natural disasters, damages caused by moisture or liquids entering the device (device and it's accessories are not waterproof or water resistant!), damages made by improper installation, extreme conditions, improper usage of the device, by wear or by the car accident. Dash7" is product which requires professional installation by an experienced technician. Failure to do so may void the warranty. Warranty also does not cover damages or defects created during shipping if they were not reported to the shipping company when the package was delivered.

**Warranty is also void if the Warranty seals have been broken, if anyone has opened or modified the device or its accessories!**

All warranty repairs or modifications must be performed by the manufacturer or its authorized services, otherwise the product will void the warranty.

**WARNING! Product is not designed for using on public roads!**

✂ -----

## WARRANTY CARD

for V3MS Dash7" Gen2 devices

-----  
Stamp and signature of the workshop that installed this device

-----  
Date of installation

-----  
Vehicle: Mark, Model, VIN, Year

-----  
Dash7 Serial number

✂ -----

All information in this manual are for informational purposes only, may not be considered immutable and the manufacturer reserves the right to change these informations or device specifications at any time without prior notice. Printing errors reserved.

The manufacturer is not liable for any damage caused by following instructions in this manual or improper use, improper connection, improper installation or modification of the device.

The information in this manual must not be considered binding and the installation must be carried out by a professionally trained person trained in working with automotive electronics and electronic devices.

This manual is valid for 2024 and newer Spec devices only (HW23 Rev3).

This is the 5<sup>th</sup> revision of this document, published 10/2024.

Copyright ITALPOL RACING, Slovakia 2022-2024, V3MS Motorsport Solutions